

Level 2 Award and Certificate, & Level 3 Award,
Certificate, Diploma in Fabrication and Welding Practice

But Weld for all MMA, MAGS, TAGS and O/A units.

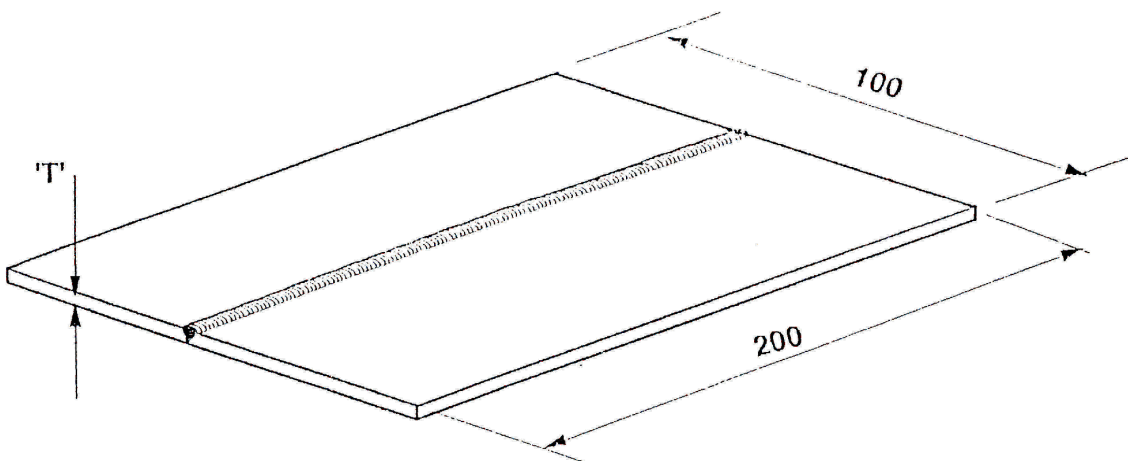

Specimen Length 200mm must be adhered to

SPECIMEN CUTTING AND TESTING

Following visual inspection and marketing, Cut 75mm of continuous penetration from the test piece to accommodate TWO bend tests at 35mm each - one face bend and one root bend.

From the remainder of the test piece 35mm should be cut out for the nick-break fracture test

In summary THREE 35mm sections are required for the following:

One root bend test prepared and bent to 90° e.g. "A"

One face bend test prepared and bent to 90° e.g. "B"

One Fracture to include a marked stop/restart position e.g. "C"

