

Level 2 Award and Certificate, & Level 3 Award,
Certificate, Diploma in Fabrication and Welding Practice

Fillet Weld for all MMA, MAGS, TAGS and O/A units.

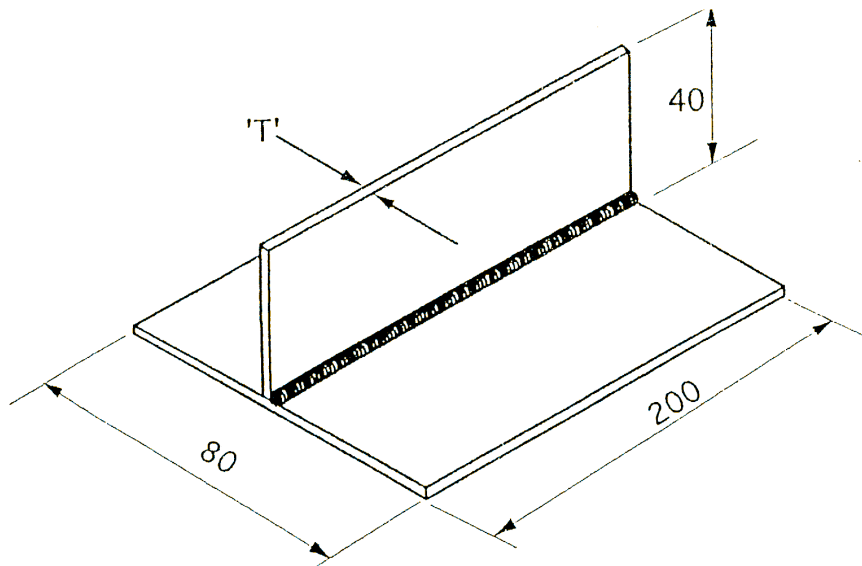

Specimen length 200mm must be adhered to.

SPECIMEN CUTTING AND TESTING

Cut test piece into THREE equal pieces - A, B & C = 5mm minimum.
Macro-etch the stop/restart position = 1/3 specimen distance from one end.
After visual inspection and making, nick-break fracture all THREE test coupons.

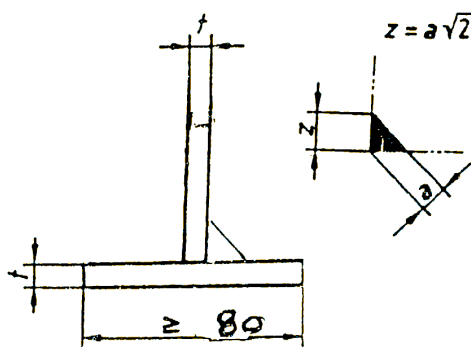

For $t \geq 6$ mm, $a \leq 0,5t$
For $t < 6$ mm, $0,5t \leq a \leq t$
($z \approx 0,7t$)

All Fillet Welds dimensioned by Leg Length

